

# **GALVANITE K. D. WARDROBE STOCK LOCKER ASSEMBLY INSTRUCTIONS**

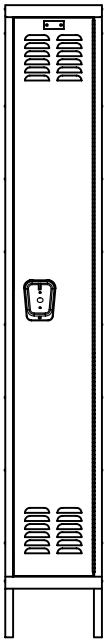

1 WIDE

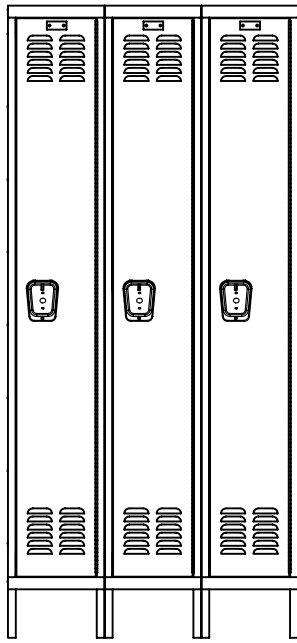

3 WIDE

SINGLE TIER

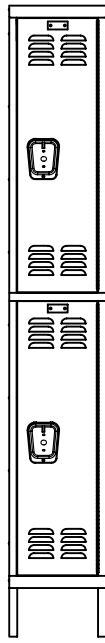

1 WIDE

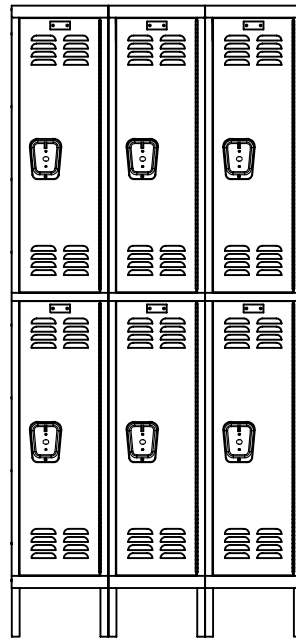

3 WIDE

DOUBLE TIER

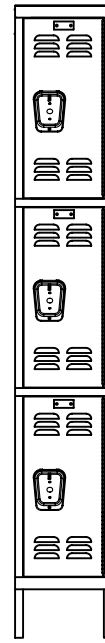

1 WIDE

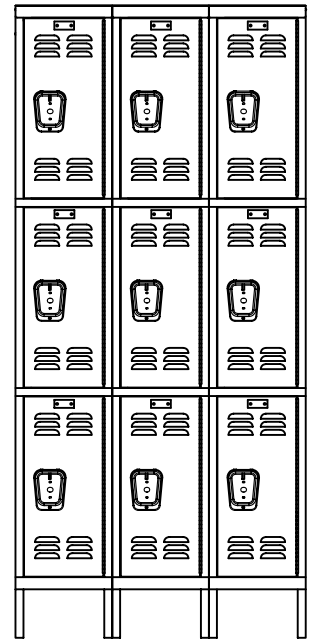

3 WIDE

TRIPLE TIER

## **General Instructions**

1. Check material received against the packing list. First check the number of packages received and then check the contents of each package.
2. Check material received for damage. If damage has occurred, secure a "damage notation" from the carrier.
3. Identify each part as it is unpacked and put like parts together as close as possible to the working area in which they are to be assembled.
4. Be careful to use the correct hardware as specified in the assembly instructions.
5. Items with suffix (xx) are available options.

## **CAUTION**

IN THE INTEREST OF SAFETY, ALL LOCKERS MUST BE SECURELY ANCHORED TO THE FLOOR AND/OR WALL.  
FOR SAFETY, HANDLE ALL COMPONENTS CAREFULLY AND WEAR WORK-GLOVES WHEN ASSEMBLING LOCKERS.

INSTALL ALL UNITS PLUMB AND TIGHTEN ALL HARDWARE SECURELY.

RETAIN INSTRUCTIONS FOR FUTURE REFERENCE.



401 Jim Moran Blvd., P.O. Box 9601  
Deerfield Beach, FL 33442

Phone (954) 429-9155  
Fax (954) 428-3843

**[www.ListIndustries.com](http://www.ListIndustries.com)**

# GALVANITE K. D. WARDROBE STOCK LOCKER ASSEMBLY INSTRUCTIONS

## PACKAGE CONTENTS

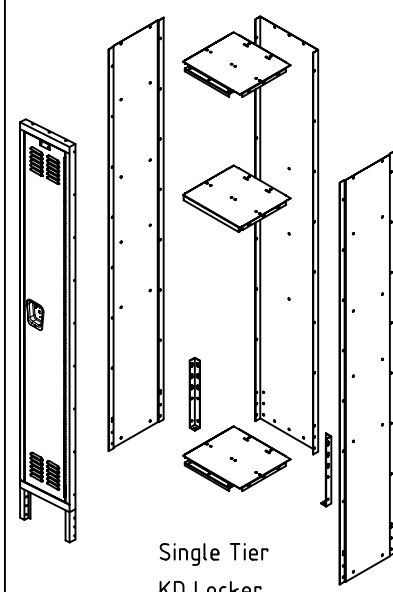
REF. NO.	DESCRIPTION	PART NO.	1-WIDE QUANTITY			3-WIDE QUANTITY			
			1-TIER	2-TIER	3-TIER	1-TIER	2-TIER	3-TIER	
①	REAR PANEL	KRwwhhG	1	1	1	3	3	3	 <p>Single Tier KD Locker</p> <p>PART NUMBER SUFFIX SHOWS WIDTH, DEPTH, HEIGHT AND TIER. CUSTOMER TO SPECIFY.</p>
②	RIGHT/LEFT SIDE PANEL	KPddhhG	2	2	2	4	4	4	
③	TOP/BOTTOM SHELF	KSwwddG	2	3	4	6	9	12	
④	HAT SHELF	KHwwddG	1	-	-	3	-	-	
⑤	SINGLE CEILING HOOK	H5K	2	4	-	6	12	-	
⑥	DOUBLE CEILING HOOK	H7K	1	2	3	3	6	9	
xx⑦	COAT ROD BRACKET	xxTRH200	xx2	xx4	-	xx6	xx12	-	
xx⑧	COAT ROD	xxKCRww	xx1	xx2	-	xx3	xx6	-	
⑨	DOOR FRAME ASSEMBLY	KDFwwhh-tG	1	1	1	3	3	3	
x⑩	DOOR	KDwwhh-tG	1	2	3	3	6	9	
x⑪	RECESSED HANDLE S.S.	TBECK2	1	2	3	3	6	9	
x⑫	LOCK CHANNEL	KLhh-t	1	2	3	3	6	9	
x⑬	CHANNEL STOP	CS002	2	4	6	6	12	18	
x⑭	NYLON LATCH	DLB100B	2	4	6	6	12	18	
x⑮	SPRING	LS100	2	4	6	6	12	18	
x⑯	LOCK BRACKET	SLB101L	1	2	3	3	6	9	
x⑰	PLASTIC LIFTER	LC100B	1	2	3	3	6	9	
⑱	REAR LEG	KLG	2	2	2	2	2	2	
x⑲	BUMPER	KDB300	3	4	6	9	12	18	
⑳	NUMBER PLATE	NPL	1	2	3	3	6	9	
㉑	NUMBER PLATE RIVET	RV101	2	4	6	6	12	18	
㉒	3/8" SLOTLESS BOLT	MBT200	62	74	70	134	166	188	
㉓	HEX NUT	N201	60	70	64	128	154	170	
㉔	ESCUTCHEON PLATE	RPE100	1	2	3	3	6	9	
㉕	HI-DOME CAP NUT	N110	2	4	6	6	12	18	
x㉖	RIVET (HANDLE)	RV102	1	2	3	3	6	9	
x㉗	RIVET (HINGE)	RV102	7	8	9	21	24	27	

### NOTE:

FOR OPTIONAL INDIVIDUAL SLOPE TOPS,  
SEE SUPPLEMENTAL INSTRUCTION SHEET NO. ASY-L-KIST-A

FOR OPTIONAL 6" HIGH CLOSED METAL BASE,  
SEE SUPPLEMENTAL INSTRUCTION SHEET NO. ASY-L-KIST-B

- x SHIPS PRE-HUNG IN DOOR FRAME ASSEMBLY ⑨
- xx OPTIONAL ITEM

### PART NO. LEGEND:

ww = WIDTH  
dd = DEPTH  
hh = HEIGHT (FRAME)  
t = TIER

**TOOLS REQUIRED: 3/8" NUT  
DRIVER (3/8" SOCKET MAY BE  
SUBSTITUTED)**

## TWO-YEAR WARRANTY

LIST INDUSTRIES K.D. LOCKERS ARE COVERED AGAINST ALL DEFECTS IN MATERIALS AND WORKMANSHIP EXCLUDING FINISH, DAMAGE RESULTING FROM DELIBERATE DESTRUCTION AND VANDALISM FOR A PERIOD OF TWO YEARS.



# GALVANITE K. D. WARDROBE STOCK LOCKER ASSEMBLY INSTRUCTIONS

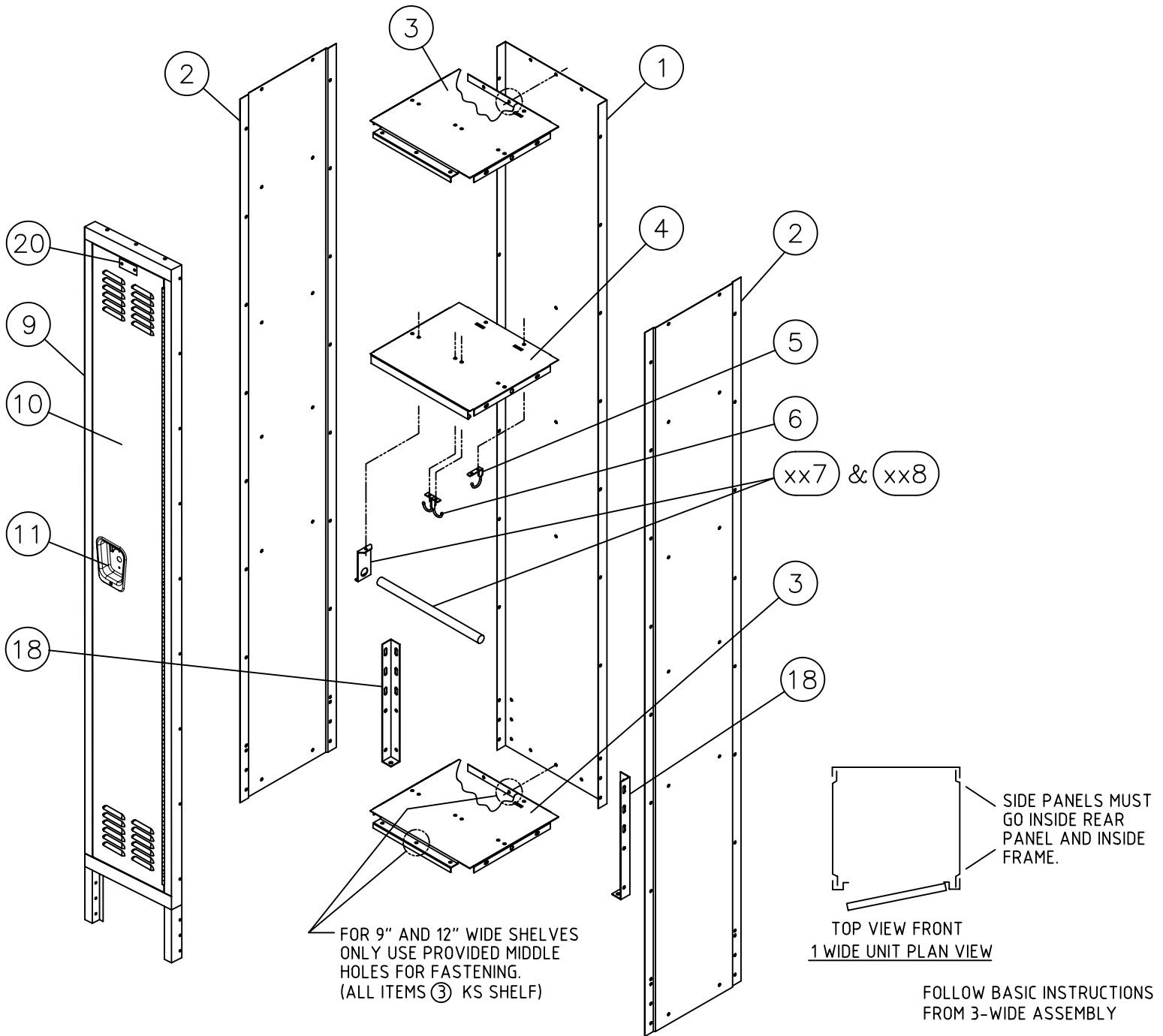

COAT ROD (KCR<sub>ww</sub>) & COAT ROD BRACKETS (TRH 200) ARE OPTIONAL.

LIST INDUSTRIES MAKES EVERY EFFORT TO ENSURE THAT ALL UNITS SHIP COMPLETE; HOWEVER, SHOULD YOUR UNIT CONTAIN MISSING OR DAMAGED PARTS, REPLACEMENTS MAY BE OBTAINED FROM LIST INDUSTRIES. TO OBTAIN PARTS, FOLLOW THESE INSTRUCTIONS.

## PLEASE PROVIDE THE FOLLOW INFORMATION:

MODEL NUMBER

PURCHASE DATE

DESCRIPTION OF PART(S) NEEDED & PART NUMBER(S) AS SHOWN IN PARTS LIST

COMPANY NAME & CONTACT PERSON

COLOR

WHERE THE PRODUCT WAS PURCHASED FROM

IF REQUESTING PARTS BY TELEPHONE, ASK FOR CUSTOMER SERVICE & PROVIDE THE ABOVE INFORMATION.



# GALVANITE K.D. WARDROBE STOCK LOCKER ASSEMBLY INSTRUCTIONS

(A GROUPING OF 3-WIDE SINGLE TIER LOCKERS ILLUSTRATED)

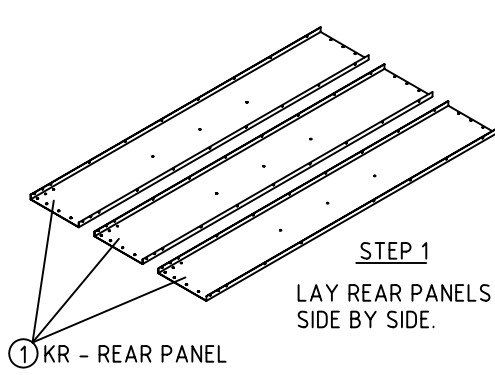

**STEP 1**  
LAY REAR PANELS  
SIDE BY SIDE.

① KR - REAR PANEL

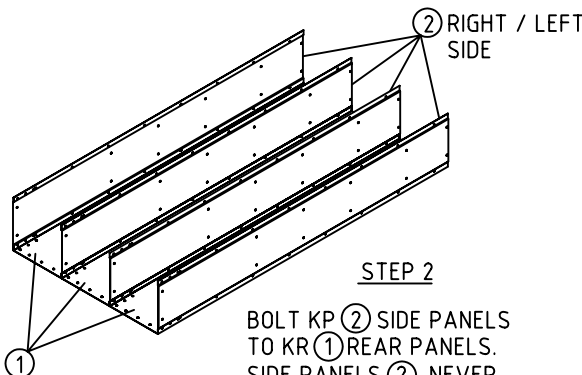

**STEP 2**

BOLT KP ② SIDE PANELS  
TO KR ① REAR PANELS.  
SIDE PANELS ② NEVER  
FIT BETWEEN KR ① REAR  
PANEL FLANGES.

①

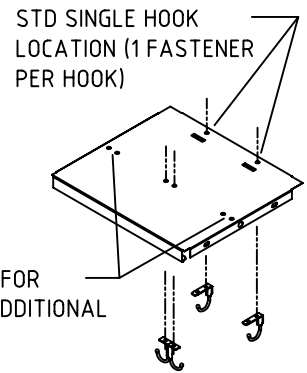

STD SINGLE HOOK  
LOCATION (1 FASTENER  
PER HOOK)

SIDE HOLES FOR  
OPTIONAL ADDITIONAL  
HOOKS.

**STEP 3**

INSTALL DOUBLE CEILING  
HOOK (H7K) ⑥ AND SINGLE  
CEILING HOOKS (H5K) ⑤  
TO (KH) ④ HAT SHELF.

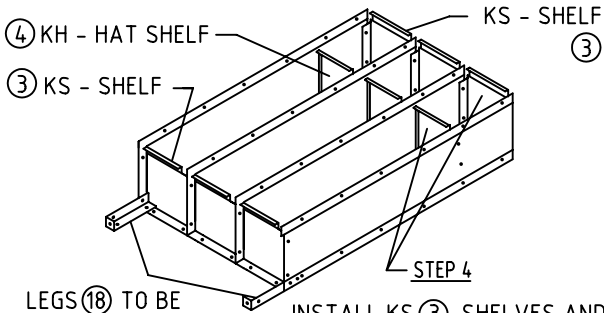

**STEP 4**

LEGS ⑱ TO BE  
AT 36" INTERVALS

INSTALL KS ③ SHELVES AND  
KH ④ SHELVES TO UNIT.  
INSTALL TWO KLG ⑱ REAR  
LEGS TO INSIDE OF SIDE ② AND REAR  
PANEL ① BY SLIDING INTO PLACE FROM BOTTOM.

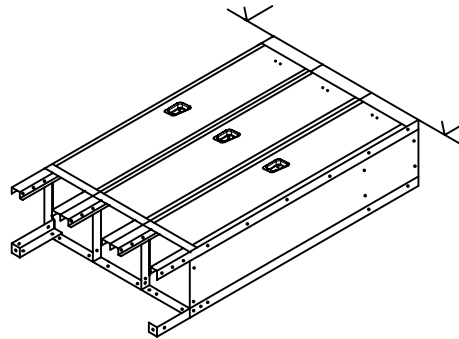

**STEP 5**

BOLT DOOR AND FRAME ⑨ ASSEMBLIES  
TO KS ③ SHELVES AND KP ② SIDE  
PANELS. STAND UNIT UP AND ALIGN  
LOCKER TOPS EVENLY. TIGHTEN ALL  
BOLTS AND NUTS.

NOTE: WHEN BOLTING ONE UNIT TO  
ANOTHER, OMIT ONE SET OF BOLTS  
IN END FRAME AND SIDE TO MINIMIZE  
GROWTH FROM BOLT HEADS.

ASSEMBLY OF SINGLE ROW LOCKERS  
NEVER PUT SIDE PANELS BETWEEN  
FRAMES OR REAR PANELS.

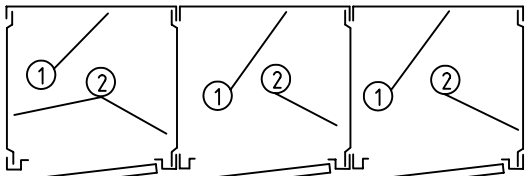

SINGLE TIER EXAMPLE - 3 WIDE UNIT PLAN VIEW

SIDE PANELS MUST  
GO INSIDE REAR  
PANEL AND INSIDE  
FRAME.

## OPTIONAL COAT ROD

BRACKETS TO BE BOLTED TO UNDERSIDE  
OF HAT SHELF WITH COAT ROD IN BETWEEN.

xx ⑦ COAT ROD BRACKETS (xxTRH 200)

xx ⑧ COAT ROD (xxKCRww)

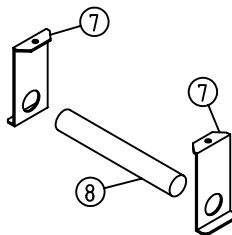

⑥ DOUBLE CEILING HOOK (H7K)

TO BE BOLTED TO  
UNDERSIDE OF HAT SHELF.



⑤ SINGLE CEILING HOOK (H5K)

TO BE BOLTED TO  
UNDERSIDE OF HAT SHELF.

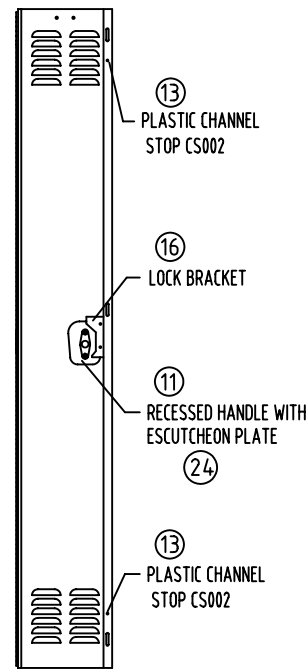

INSIDE DOOR VIEW

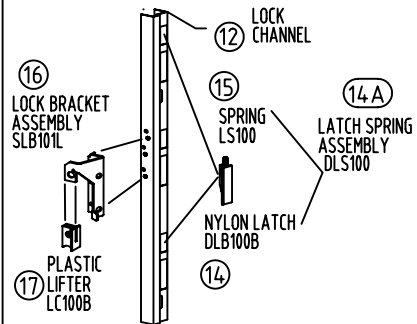

EXPLODED VIEW OF LOCK CHANNEL

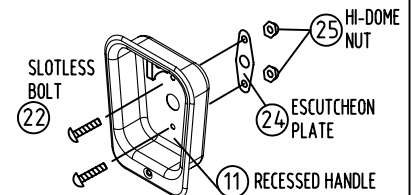

ASSEMBLY OF ESCUTCHEON PLATE

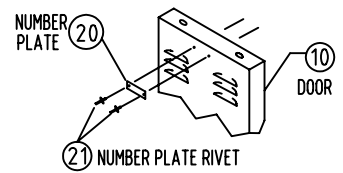

ASSEMBLY OF NUMBER PLATE